

## Type BUI 絕緣護管套 Insulated Bushings

規格 Trade Size Inches	型號 Catalog Number			螺紋 Thread	尺寸 Dimensions in (mm)			
	A	B	C		D			
1/2	BUI01	BUI01 -D	BUI01 -A	NPT or BSPT	29	15	10.4	13
3/4	BUI02	BUI02 -D	BUI02 -A		35	21	13	15
1	BUI03	BUI03 -D	BUI03 -A		44	25	15	17
1 1/4	BUI04	BUI04 -D	BUI04 -A		54	32.8	18.5	21
1 1/2	BUI05	BUI05 -D	BUI05 -A		61	36.6	16	18
2	BUI06	BUI06 -D	BUI06 -A		77	47	18	21.5
2 1/2	BUI07	BUI07 -D	BUI07 -A		90	60.8	25.6	28
3	BUI08	BUI08 -D	BUI08 -A		103	73.8	28	31
4	BUI09	BUI09 -D	BUI09 -A		130	100	31	35
5	BUI10	BUI10 -D	BUI10 -A		159	119	27	31
6	BUI11	BUI11 -D	BUI11 -A		183	123	34	39
材質 Standard Material	鑄鐵 Cast Iron	延性鑄鐵 Ductile Iron	鋁合金 Aluminum Alloy	FEATURES : ● Zinc plated of type BUI and BUI-D ● Painted of type BUI-A ● Optional Finish : Hot Dip Galvanized or Zinc Themospray are available.				
表面處理 Standard Finish	電鍍鋅 Zinc plated	熱噴鋅 Zinc Themospray	噴漆 Painted					

◎另可提供熱噴鋅表面處理◎

## Type LN 制止螺帽 Locknuts

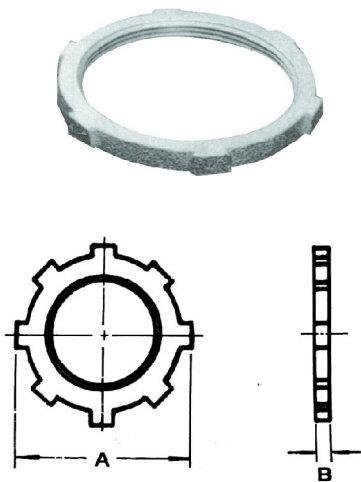

規格 Trade Size Inches	型號 Catalog Number		螺紋 Thread	尺寸 Dimensions in (mm)	
	A	B			
1/2	LN01-S(Steel)		NPT or BSPT	33	3.5
3/4	LN02-S(Steel)			38	4
1	LN03-S(Steel)			46	4
1 1/4	LN04-S(Steel)			56	4.8
1 1/2	LN05-S(Steel)			65	4.2
2	LN06-S(Steel)			81	6
2 1/2	LN07	LN07 -D		98	9.3
3	LN08	LN08 -D		111	10
4	LN09	LN09 -D		140	11
5	LN10	LN10 -D		169	14
6	LN11	LN11 -D		200	16.5
材質說明 : 1/2" ~2" 為鋼 (steel) 製成 2 1/2~4" LN為鑄鐵 LN-D為延性鑄鐵 表面處理 : 電鍍鋅 ◎另可提供熱噴鋅表面處理◎				Material : 1/2" ~2" steel 2 1/2~4" LN Cast Iron LN-D Ductile Iron Standard Finish : Zinc Plated Optional Finish : Zinc Themospray are available	

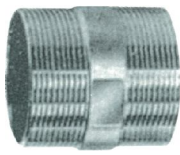

## Type NIP 外絲短管 Short Nipples

規格 Trade Size Inches	型號 Catalog NO .	螺紋 Thread	短管全長 Body Length (mm)
3/4	NIP02-S	30	
1	NIP03-S	30	
1 1/4	NIP04-S	38	
1 1/2	NIP05-S	38	
2	NIP06-S	38	
2 1/2	NIP07-S	60	
3	NIP08-S	60	
4	NIP09-S	60	

材質說明：鋼質／表面電鍍鋅  
Standard Materials : steel / Zinc plated

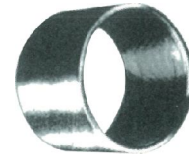

## Type CPL 內絲管節 Couplings

規格 Trade Size Inches	型號 Catalog NO .	螺紋 Thread	尺寸Dimensions in (mm)	
			A	B
1/2	CPL01-S	NPT or BSPT	25.0	38
3/4	CPL02-S		31.0	44
1	CPL03-S		37.5	50
1 1/4	CPL04-S		48.5	56
1 1/2	CPL05-S		54.5	56
2	CPL06-S		68.0	64
2 1/2	CPL07-S		84.0	72
3	CPL08-S		97.0	80
4	CPL09-S		123	90

材質說明：鋼質／熱浸鍍鋅  
Standard Materials : steel / Hot Dip Galvanized

## Type NB 電管彎管 Normal Bends

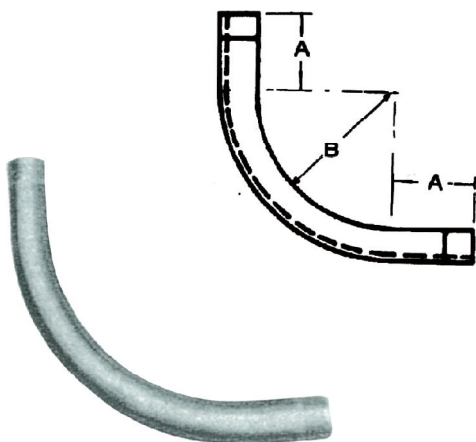

規格 Trade Size Inches	型號 Catalog NO .	螺紋 Thread	尺寸Dimensions in (mm)	
			A	B
1/2	NB01-S	NPT or BSPT	70	100
3/4	NB02-S		70	100
1	NB03-S		70	100
1 1/4	NB04-S		80	150
1 1/2	NB05-S		100	200
2	NB06-S		100	250
2 1/2	NB07-S		130	300
3	NB08-S		170	330
4	NB09-S		200	450

材質說明：鋼質／熱浸鍍鋅（6倍式大月彎管）  
Standard Materials : steel / Hot Dip Galvanized



內外牙大小頭

**Type RE Flush Type Reducers**

規格 Trade Size Inches	型號 Catalog NO.	本體全長 Body Length (mm)
1 - $\frac{1}{2}$	RE1004-S	16
1 - $\frac{3}{4}$	RE1006-S	16
$1\frac{1}{4}$ - $\frac{1}{2}$	RE1204	23
$1\frac{1}{4}$ - $\frac{3}{4}$	RE1206-S	23
$1\frac{1}{4}$ - 1	RE1210-S	23
$1\frac{1}{2}$ - $\frac{1}{2}$	RE1404	24
$1\frac{1}{2}$ - $\frac{3}{4}$	RE1406-S	24
$1\frac{1}{2}$ - 1	RE1410-S	24
$1\frac{1}{2}$ - $1\frac{1}{4}$	RE1412-S	24
2 - $\frac{1}{2}$	RE2004	29
2 - $\frac{3}{4}$	RE2006	29
2 - 1	RE2010	29
2 - $1\frac{1}{4}$	RE2012	29
2 - $1\frac{1}{2}$	RE2014-S	29
$2\frac{1}{2}$ - $\frac{1}{2}$	RE2404	34
$2\frac{1}{2}$ - $\frac{3}{4}$	RE2406	34
$2\frac{1}{2}$ - 1	RE2410	34
$2\frac{1}{2}$ - $1\frac{1}{4}$	RE2412	34
$2\frac{1}{2}$ - $1\frac{1}{2}$	RE2414	34
$2\frac{1}{2}$ - 2	RE2420-S	34
3 - $\frac{1}{2}$	RE3004	35
3 - $\frac{3}{4}$	RE3006	35
3 - 1	RE3010	35
3 - $1\frac{1}{4}$	RE3012	35
3 - $1\frac{1}{2}$	RE3014	35
3 - 2	RE3020	35
3 - $2\frac{1}{2}$	RE3024-S	35
4 - $\frac{1}{2}$	RE4004	38
4 - $\frac{3}{4}$	RE4006	38
4 - 1	RE4010	38
4 - $1\frac{1}{4}$	RE4012	38
4 - $1\frac{1}{2}$	RE4014	38
4 - 2	RE4020	38
4 - $2\frac{1}{2}$	RE4024	38
4 - 3	RE4030-S	38

- Male - Female Threads
- RE type cast Iron, zinc plated.
- RE - S type steel, zinc plated.
- Threads NPT or BSPT

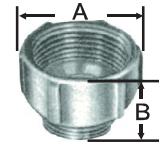

內外牙放大接頭

**Type ME Male Enlargers**

規格 Trade Size Inches	型號 Catalog NO.	Dimensions in (mm)	
		A	B
$\frac{1}{2}$ - $\frac{3}{4}$	ME0406	39	43
$\frac{1}{2}$ - 1	ME0410	53	50
$\frac{1}{2}$ - $1\frac{1}{4}$	ME0412	58	54
$\frac{1}{2}$ - $1\frac{1}{2}$	ME0414	70	58
$\frac{1}{2}$ - 2	ME0420	76	64
$\frac{1}{2}$ - $2\frac{1}{2}$	ME0424	95	75
$\frac{1}{2}$ - 3	ME0430	115	80
$\frac{1}{2}$ - 4	ME0440	140	85
$\frac{3}{4}$ - 1	ME0610	53	50
$\frac{3}{4}$ - $1\frac{1}{4}$	ME0612	58	54
$\frac{3}{4}$ - $1\frac{1}{2}$	ME0614	70	58
$\frac{3}{4}$ - 2	ME0620	76	64
$\frac{3}{4}$ - $2\frac{1}{2}$	ME0624	95	75
$\frac{3}{4}$ - 3	ME0630	115	85
$\frac{3}{4}$ - 4	ME0640	140	85
1 - $1\frac{1}{4}$	ME1012	58	54
1 - $1\frac{1}{2}$	ME1014	70	58
1 - 2	ME1020	76	67
1 - $2\frac{1}{2}$	ME1024	95	78
1 - 3	ME1030	115	80
1 - 4	ME1040	140	85
$1\frac{1}{4}$ - $1\frac{1}{2}$	ME1214	70	60
$1\frac{1}{4}$ - 2	ME1220	76	67
$1\frac{1}{4}$ - $2\frac{1}{2}$	ME1224	95	78
$1\frac{1}{4}$ - 3	ME1230	115	80
$1\frac{1}{4}$ - 4	ME1240	140	85
$1\frac{1}{2}$ - 2	ME1420	76	69
$1\frac{1}{2}$ - $2\frac{1}{2}$	ME1424	95	80
$1\frac{1}{2}$ - 3	ME1430	115	80
$1\frac{1}{2}$ - 4	ME1440	140	89
2 - $2\frac{1}{2}$	ME2024	96	80
2 - 3	ME2030	115	85
2 - 4	ME2040	140	89
$2\frac{1}{2}$ - 3	ME2430	115	85
$2\frac{1}{2}$ - 4	ME2440	140	89
3 - 4	ME3040	140	90

- Male - Female Threads
- Cast Iron, Zinc plated.
- Threads NPT or BSPT

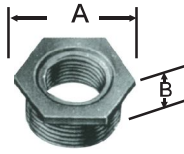

內外牙縮小接頭

## Type ADP Adapters

規格 Trade Size Inches	型號 Catalog NO .	Dimensions in (mm)	
		A	B
3/4 - 1/2	ADP0604-M	35	21
1 - 1/2	ADP1004-M	42	21
1 - 3/4	ADP1006-M	42	21
1 1/4 - 1/2	ADP1204-M	53	28
1 1/4 - 3/4	ADP1206-M	53	28
1 1/4 - 1	ADP1210-M	53	28
1 1/2 - 1/2	ADP1404-M	63	30
1 1/2 - 3/4	ADP1406-M	63	30
1 1/2 - 1	ADP1410-M	63	30
1 1/2 - 1 1/4	ADP1412-M	63	30
2 - 1/2	ADP2004-M	67	35
2 - 3/4	ADP2006-M	67	35
2 - 1	ADP2010-M	67	35
2 - 1 1/4	ADP2012-M	67	35
2 - 1 1/2	ADP2014-M	67	35
2 1/2 - 1/2	ADP2404-M	85	36
2 1/2 - 3/4	ADP2406-M	85	36
2 1/2 - 1	ADP2410-M	85	36
2 1/2 - 1 1/4	ADP2412-M	85	36
2 1/2 - 1 1/2	ADP2414-M	85	36
2 1/2 - 2	ADP2420-M	85	36
3 - 1/2	ADP3004-M	101	45
3 - 3/4	ADP3006-M	101	45
3 - 1	ADP3010-M	101	45
3 - 1 1/4	ADP3012-M	101	45
3 - 1 1/2	ADP3014-M	101	45
3 - 2	ADP3020-M	101	45
3 - 2 1/2	ADP3024-M	101	45
4 - 1/2	ADP4004-M	128	48
4 - 3/4	ADP4006-M	128	48
4 - 1	ADP4010-M	128	48
4 - 1 1/4	ADP4012-M	128	48
4 - 1 1/2	ADP4014-M	128	48
4 - 2	ADP4020-M	128	48
4 - 2 1/2	ADP4024-M	128	48
4 - 3	ADP4030-M	128	48

材質說明：可鍛鑄鐵／熱浸鍍鋅  
Material & Finish : Malleable Iron, Hot Dip Galvanized

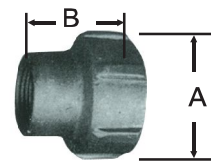

內牙大小頭

## Type REC Reducing Couplings

規格 Trade Size Inches	型號 Catalog NO .	Dimensions in (mm)	
		A	B
3/4 - 1/2	REC0604-M	35	40
1 - 1/2	REC1004-M	43	45
1 - 3/4	REC1006-M	43	45
1 1/4 - 1/2	REC1204-M	58	53
1 1/4 - 3/4	REC1206-M	58	53
1 1/4 - 1	REC1210-M	58	53
1 1/2 - 1/2	REC1404-M	61	52
1 1/2 - 3/4	REC1406-M	61	52
1 1/2 - 1	REC1410-M	61	52
1 1/2 - 1 1/4	REC1412-M	61	52
2 - 1/2	REC2004-M	73	52
2 - 3/4	REC2006-M	73	58
2 - 1	REC2010-M	73	58
2 - 1 1/4	REC2012-M	73	58
2 - 1 1/2	REC2014-M	73	58
2 1/2 - 1/2	REC2404-M	95	75
2 1/2 - 3/4	REC2406-M	95	75
2 1/2 - 1	REC2410-M	95	78
2 1/2 - 1 1/4	REC2412-M	95	78
2 1/2 - 1 1/2	REC2414-M	95	80
2 1/2 - 2	REC2420-M	95	80
3 - 1/2	REC3004-M	115	80
3 - 3/4	REC3006-M	115	80
3 - 1	REC3010-M	115	80
3 - 1 1/4	REC3012-M	115	80
3 - 1 1/2	REC3014-M	115	80
3 - 2	REC3020-M	115	85
3 - 2 1/2	REC3024-M	115	85
4 - 1/2	REC4004-M	140	85
4 - 3/4	REC4006-M	140	85
4 - 1	REC4010-M	140	85
4 - 1 1/4	REC4012-M	140	85
4 - 1 1/2	REC4014-M	140	89
4 - 2	REC4020-M	140	89
4 - 2 1/2	REC4024-M	140	89
4 - 3	REC4030-M	140	90

材質說明：可鍛鑄鐵／熱浸鍍鋅  
Material & Finish : Malleable Iron, Hot Dip Galvanized



**Type PLR 內凹管塞頭**  
Plugs (Recessed)

規格 Trade Size Inches	型號 Catalog NO.	螺紋 Thread	本體全長 Body Length (mm)
1/2	PLR01	NPT or BSPT	15
3/4	PLR02		17
1	PLR03		19
1 1/4	PLR04		22
1 1/2	PLR05		23
2	PLR06		23
2 1/2	PLR07		27
3	PLR08		30
4	PLR09		35

材質說明：鑄鐵／表面電鍍鋅處理  
Standard Materials : Cast Iron / Zinc plated



**Type PLS 外牙管塞頭**  
Plugs (Squared)

規格 Trade Size Inches	型號 Catalog NO.	螺紋 Thread	本體全長 Body Length (mm)
1/2	PLS01-M	NPT or BSPT	25
3/4	PLS02-M		28
1	PLS03-M		32
1 1/4	PLS04-M		35
1 1/2	PLS05-M		32
2	PLS06-M		38
2 1/2	PLS07-M		48
3	PLS08-M		52
4	PLS09-M		60

材質說明：可鍛鑄鐵／熱浸鍍鋅  
Standard Materials : Malleable Iron / Hot Dip Galvanized

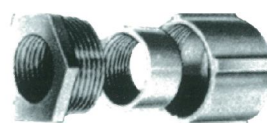
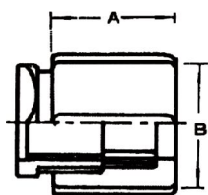

**Type UC 三合式由任管節 3-Piece Couplings**

規格 Trade Size Inches	型號 Catalog Number			螺紋 Thread	尺寸 Dimensions in (mm)	
	*	*	*		A	B
1/2	*	*	*	NPT or BSPT	*	*
3/4	UC02	UC02 -D	UC02 -A		35	50
1	UC03	UC03 -D	UC03 -A		41	56
1 1/4	UC04	UC04 -D	UC04 -A		48	60
1 1/2	UC05	UC05 -D	UC05 -A		50	74
2	UC06	UC06 -D	UC06 -A		56	88
材質 Standard Material	鑄鐵 Cast Iron	延性鑄鐵 Ductile Iron	鋁合金 Aluminum Alloy	FEATURES : ● Zinc plated of type UC and UC-D ● Painted of type UC-A ● Optional Finish : Hot Dip Galvanized or Zinc Therospray are available.		

表面處理：鑄鐵類 電鍍鋅 鋁合金 噴漆  
(另可提供熱浸鍍鋅或熱噴鋅表面處理)